

URBAN LIGHTLINE SUSPENSION design Massimo Tonetto

Suspended lamp with direct and indirect light. Light burnished brass structure and matte black perforated metal lampshade.



SYDNEY - MELBOURNE - GOLD COAST - PERTH - AUCKLAND
G45, 76-84 WATERWAY DRIVE COOMERA, QLD, 4209, AUSTRALIA

Phone: +61 417 950 455

Email: showroom@gineico.com

WWW.GINEICOLIGHTING.COM.AU

URBAN LIGHTLINE SUSPENSION

Function	Suspension
Location	Interior
Light Emission	Direct and indirect light
Light Source	1•50W LED 5475lm 2700°K Dimmable 0-10V 1-10V -DALI -Push Botton
Rated Voltage	110 - 120 V / 220 - 240 V
Frequency	50 - 60 Hz
Supply	Terminal block
Ballast	Dimmable ballast included
Wiring cable lenght	250cm -98"4
Steel cable lenght	250cm -98"4

Certifications

UL/CE   IP20

Structure

M11 Light burnished brass
+ +
MB Matte black

Package	Dimensions	Net Weight	Gross Weight
	180x58xH.30cm (70"9x22"8xH.11"8)	8kg	13kg
			0,31 m3

Dimensions

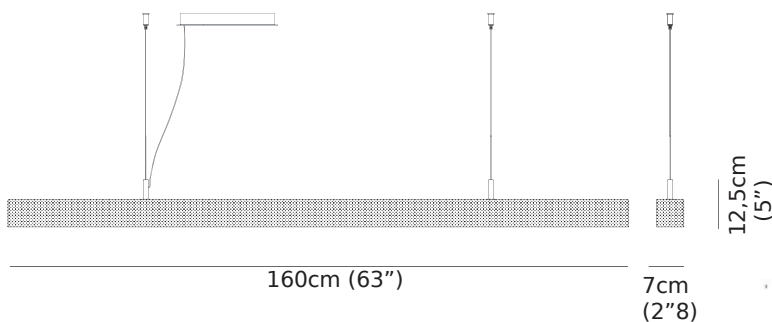

Kit j-box

